

INDUSTRIAL WEIGHING SOLUTION™



Large LCD display



Portable type



Disattachable display



Disattachable display

# PB SERIES

## Portable Bench

- Easy to carry portable type
- Write backlight
- Disattachable display
- Auto power-off
- Auto zero tracking
- Available capacity : 30kg~200kg
- Battery operating : UP to 300 hours of continuous use

## Major places of use

- ▶ Home delivery companies
- ▶ Farm products, Dried fish, Fruits & Vegetables
- ▶ Meat processing companies



**CAS**



# PB SERIES | Portable Bench

## SPECIFICATIONS

Model	PB series			
Max.capacity (kg)	30	60	150	200
Readability (g)	5/10	10/20	20/50	50/100
External resolution	1/2,000 ~ 1/3,000(dual)			
Display digit	6 digits (weight)			
Display type	LCD			
Operating temperature	-10°C ~ +40°C			
Power	Battery, AC adapter			
Battery life	Alkaline battery: 300hrs / Mn battery: 140hrs			
Platter size (mm)	355(W) x 443(D)			
Dimensions (mm)	355(W) x 611(D) x 65(H)			
Product weight (kg)	6.2			

## FEATURES

- Easy-to-carry portable type
- Dividing LCD display and body
- Write backlight
- Battery operating  
UP to 300 hours of continuous use
- Auto power-off
- Auto zero tracking
- Available capacity : 30kg~200kg



## OPTIONS

- Rechargeable battery
- RS-232C interface

## Customizing : Burden cover design



## Major places to be used



- ▶ Home delivery companies
- ▶ Farm products, Dried fish, Fruits & Vegetables
- ▶ Meat processing companies
- ▶ Hospital, School, Fitness center

## DIMENSIONS

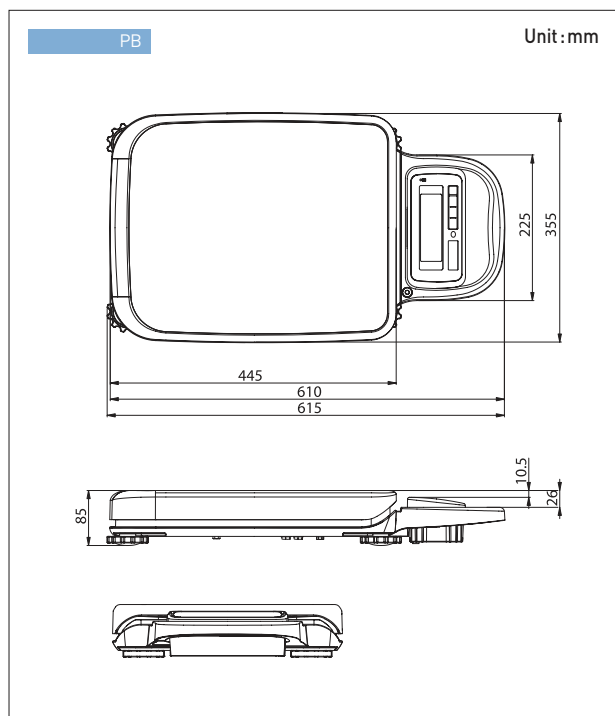

# CAS

CAS BLDG., # 440-1, SUNGNAE -DONG,  
GANGDONG-GU, SEOUL, KOREA

TEL\_ 82 2 2225 3500

FAX\_ 82 2 475 4668

<http://www.globalcas.com>

Specifications are subject to change for improvement without prior notice.

C-42709002