

# AS.R ANALYTICAL BALANCES



release date 01-03-2016



✓ Removable glass parts: side, top and back!

## Quick access to information

Direct access to functions and databases is possible from the level of keyboard.

**Database** – a direct access to databasis

**Function** - a direct access to the basic functions  
**F1 to F4** – programmable function and navigation keys on the menu

## ALIBI memory

The used ALIBI memory is a data secure area and allows to record up to 100 000 weighment records. It ensures security of constant data register in the long time period.

The AS.R series represents a new standard level for analytical balances. They feature a **new, readable LCD display** which allows a clearer presentation of the weighing result. Besides, the display has a new text information line allowing to show additional messages and data, e.g. product name or tare value.

Additionally, the new R series balances by means of pictograms signal the activated working mode, connection with the Internet, the battery charge level, balance service functions. Also a number of displayed measuring units has been increased.

The balance precision and the measurement accuracy is assured by automatic internal adjustment, which takes into consideration temperature changes and time flow.

AS.R series balances feature several communication interfaces: **2 x RS 232, type A USB, type B USB and optional WiFi**. The housing is made of plastic, and the pan is made of stainless steel.

## DATABASES IN R SERIES BALANCES

In new AS.R series balances the information system is based on 5 databases, which allows for several users to work with several products databases, and the registered weighing results can be subject to further analysis.

### The data is registered in 5 databases:

- users (up to 10 users),
- products (up to 1000 products),
- weighments (up to 5000 weighments),
- tares (up to 100 tares),
- ALIBI memory (up to 100 000 weighments).

There is two directions **data exchange** within the system thanks to a quick USB interface. New balances allow to import and export databases using **USB pen drives**.

R series balances fulfill GLP requirements.

- Parts counting
- Dosing
- Checkweighing
- Percent deviations
- Statistics
- Animal weighing
- Pipettes calibration
- Statistical Quality Control
- Autotest (GLP, Filter)
- GLP procedures
- Under hook weighing
- Totalizing
- Density determination
- Peak hold
- Packaged Goods Control
- Newton unit measurement
- Replaceable units
- ALIBI Memory

## Technical specification:

	AS 62.R2 <b>M</b>	AS 60/220.R2 <b>M</b>	AS 82/220.R2 <b>M</b>
Max capacity	62 g	60 g / 220 g	82 g / 220 g
Minimum load	1 mg	1 mg	1 mg
Readability	0,01 mg	0,01 mg / 0,1 mg	0,01 mg / 0,1 mg
Tare range	-62 g	-220 g	-220 g
Repeatability *	0,015 mg (Rt ≤ 2 g)	0,015 mg (Rt ≤ 2 g)	0,015 mg (Rt ≤ 2 g)
	0,02 mg (2 g < Rt ≤ 50 g)	0,02 mg (2 g < Rt ≤ 50 g)	0,02 mg (2 g < Rt ≤ 50 g)
	0,03 mg (50 g < Rt ≤ 60 g)	0,03 mg (50 g < Rt ≤ 60 g)	0,03 mg (50 g < Rt ≤ 82 g)
Linearity	± 0,06 mg	± 0,06 mg (to 60 g)	± 0,06 mg (to 82 g)
		±0,2 mg (60 g ÷ 220 g)	±0,2 mg (82 g ÷ 220 g)
Pan size	open-work pan Ø 90 mm or (Ø 85 mm - option)		
Working temperature	+10° ÷ +40°C		
Relative air humidity **	40% ÷ 80%		
Stabilization time	6 s	6 s / 3,5 s	6 s / 3,5 s
Sensitivity drift	1 ppm/°C in temperature +10° ÷ +40°C		
Minimum weight (USP)	30 mg	30 mg	30 mg
Minimum weight (U = 1%, k = 2)	3 mg	3 mg	3 mg
Interface	2 x RS 232, USB-A, USB-B, WiFi - option		
Power supply***	12 ÷ 16 V DC / 2,1 A		
Adjustment/calibration	internal (automatic)		
Display	LCD (backlit)		
Net weight/Gross weight	5,4 kg / 7,5 kg	5,4 kg / 7,5 kg	5,4 kg / 7,5 kg
Packaging size	495 x 400 x 515 mm		

\* Repeatability is expressed as a standard deviation from 10 weighing cycles.

\*\* Non-condensing conditions

\*\*\* 250 mA for balances without WiFi module, 350 mA for balances with installed WiFi module

## Technical specification:

	AS 110.R2 <b>M</b>	AS 160.R2 <b>M</b>	AS 220.R2 <b>M</b>	AS 310.R2 <b>M</b>
Max capacity	110 g	160 g	220 g	310 g
Minimum load	10 mg	10 mg	10 mg	10 mg
Readability	0,1 mg	0,1 mg	0,1 mg	0,1 mg
Tare range	-110 g	-160 g	-220 g	-310 g
Repeatability *	0,1 mg (Rt ≤ 110g)	0,1 mg (Rt ≤ 160g)	0,1 mg (Rt ≤ 220g)	0,1 mg (Rt ≤ 220g) 0,2 mg (220g < Rt ≤ 310g)
Linearity	± 0,2 mg	± 0,2 mg	± 0,2 mg	± 0,3 mg
Pan size	Ø 100 mm	Ø 100 mm	Ø 100 mm	Ø 100 mm
Working temperature	+10° ÷ +40°C			
Relative air humidity **	40% ÷ 80%			
Stabilization time	3,5 s			
Sensitivity drift	1 ppm/°C in temperature +10° ÷ +40°C			
Interface	2 × RS 232, USB-A, USB-B, WiFi - option			
Power supply***	12 ÷ 16 V DC / 2,1 A			
Adjustment/calibration	internal (automatic)			
Display	LCD (backlit)			
Net weight/Gross weight	5,4 kg / 7,5 kg	5,4 kg / 7,5 kg	5,4 kg / 7,5 kg	5,4 kg / 7,5 kg
Packaging size	495×400×515 mm			

\* Repeatability is expressed as a standard deviation from 10 weighing cycles.

\*\* Non-condensing conditions

\*\*\* 250 mA for balances without WiFi module, 350 mA for balances with installed WiFi module

## Dimensions:

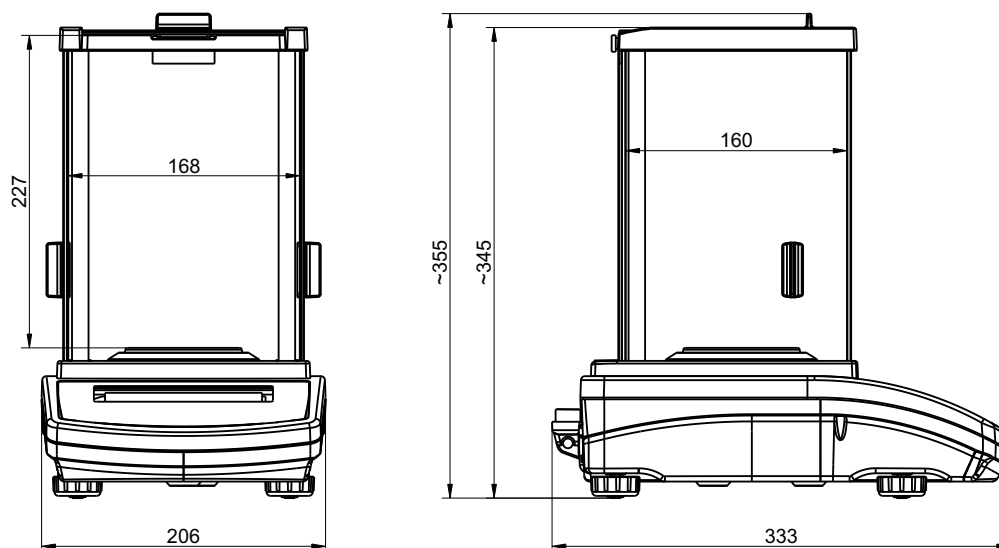

## Accessories:

Antivibration table SAL/STONE	Density determination kit
Rack for under hook weighing	Additional LCD display "WD-6"
Professional weighing table	Power adapter with battery and charger ZR-02
Impact printer Epson	PC keyboard USB
Printer USB PCL	External USB memory (FAT files format)
Holders for glass vessels	Mass standard
"PW-WIN" computer software	Adjustment weight
"RAD-KEY" computer software	USB A- USB B cable (balance - computer, balance - PLC printer)
Antistatic ionizer DJ-02	Cable RS 232 (scale - computer) "P0108"
Bar code scanner	Cable RS 232 (scale, Epson, Citizen printer) "P0151"
Bar code scanner USB HID	"Tare" or "Print" foot button