

FW500 SERIES

Simple Weighing Scale

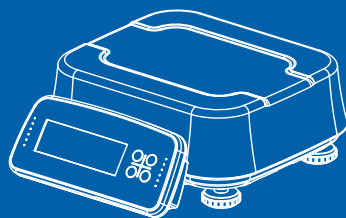

CAS

CONTENTS

PRECAUTIONS	4
PREFACE	6
NAMES AND FUNCTIONS	7
OPERATIONS	9
1. Simple Weighing Mode	9
2. Weighing with Tare	9
3. Changing Unit of Weight	10
4. Hold Function	10
5. How to Set Auto Power Off	11
6. Sleep mode	12
BATTERY MAINTENANCE	13
ERROR MESSAGE	13
SPECIFICATIONS	14

PRECAUTIONS

Warning

Precautions when installing the scale. To ensure that you get the most from your scale, please follow these instruction.

Do not disassemble the scale.

When any damage or defect occurs, contact your CAS authorized dealer immediately for proper repair.



Do not overload beyond the maximum weight limit.

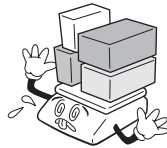

Scale must be grounded to minimize electricity static.

This will minimize defect or electric shock.



Do not pull the plug by its cord when unplugging.

Damaged cord could cause electric shock or fire.



To prevent from fire occurring, Do not place or use the scale near flammable or corrosive gas.

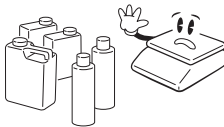

To reduce electric shock or incorrect reading, Do not spill water on the scale or place it in humid condition.

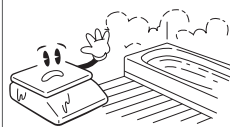

Avoid placing the scale near heater or in direct sunlight.

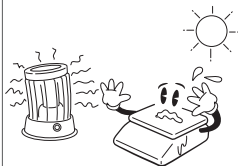

Insert plug firmly to wall outlet to prevent electric shock.

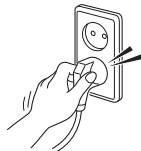

Use proper Adapter.

Incorrect adapter could damage the scale.

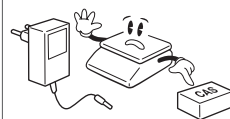

PRECAUTIONS

Attention

Make sure to plug your scal into the proper power outlet. For maximum performance, plug into a power outlet 30 minutes before the usage for warm up.

For consistent and accurate reading, maintain periodical check by your CAS authorized dealer.



Avoid sudden shock to the scale.



Grab on the bottom of the scale when moving.



Keep the scale away from other electromagnetic engering devices.

This may interfere with accurate reading.



Place the scale on firm and temperature consistent environment.



By adjusting 4 corners of the scale, set the scale even using the built in scale leveling indicator.

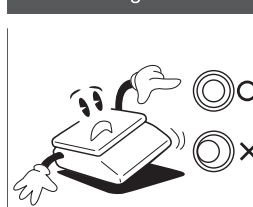

Take the battery out when scale is not in use for long time. Leakage from the batteries is hazardous.



PREFACE

Thank you for purchasing CAS FW500 Series.

These series have been designed with CAS reliability, under rigid quality control and with outstanding performance. Your special departments can enjoy these high quality reliable CAS products.

We believe that your needs will be satisfied and you will have proper reliability.

This manual will help you with proper operation and care of the FW500 Series.

Please keep it handy for future reference.

NAMES AND FUNCTIONS

OVERALL VIEW

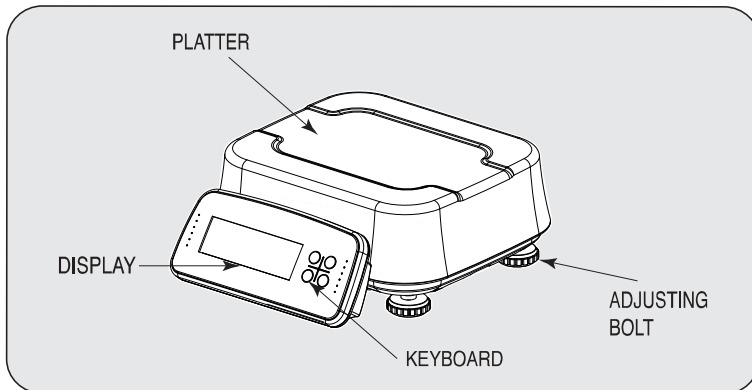

TILTING BRACKET TYPE

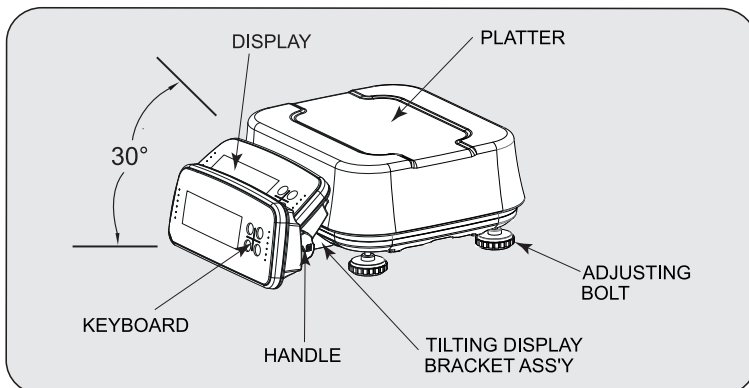

DISPLAY & KEYBOARD



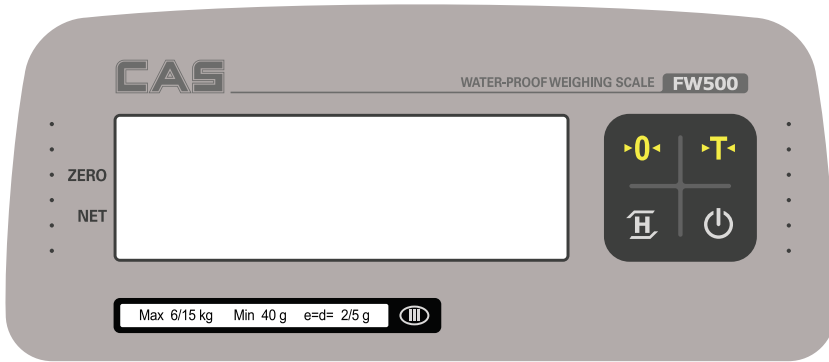

■ FW500-C (LCD Ver.)

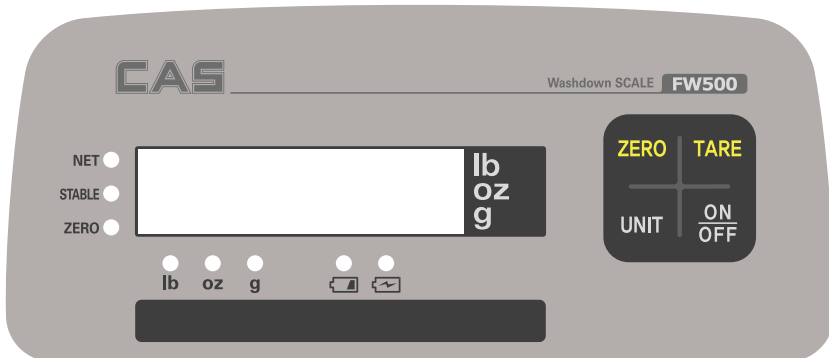





■ FW500-E (LED Ver.)



■ KEY FUNCTIONS (HOLD Ver.)

KEYS	FUNCTIONS
	Set the zero point.
	Input or cancel the weight of tare.
	Make the weight of commodity stable. This weight is average value.
	Turn on and off the scale.

■ KEY FUNCTIONS (UNIT Ver.)

KEYS	FUNCTIONS
	Set the zero point.
	Input or cancel the weight of tare.
	Make the weight of commodity stable. This weight is average value.
	Turn on and off the scale.

OPERATIONS

- Turn on the scale by pressing the  key. The display will show all the segments and count up "0" to "9". You may stop this automatic counting by pressing the **0** key.
- When you turn on the display, make sure that platter is empty. Otherwise, display will show "Err 1", an error of initial zero range. Please refer to "ERROR MESSAGE" section for more information on page 21.
- When the weight becomes stable, the display shows the stable sign (○) on.
- You may need to make it "0.000" by pressing the **0** key unless the display indicate "0.000" under the empty platter.

1. Simple Weighing Mode

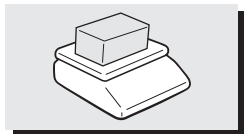

① Place a commodity on the platter.

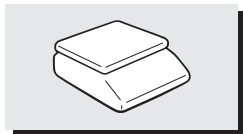

② Remove the commodity from the platter.

2. Weighing with Tare

- TARE means the weight of container being used for a commodity.
- TARE key function is to subtract the weight of the container from full weight loaded.

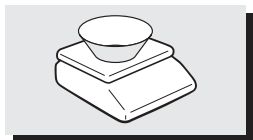

① Place a container on the platter.

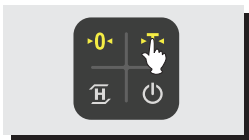

② Press the **T** key.



③ Place a commodity into the container, then the display will show only the weight of the commodity.

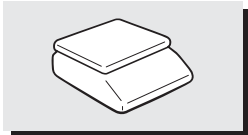
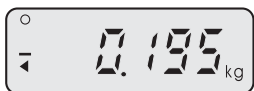

④ Remove container and commodity, then the display will show the weight of the container with "-" symbol.

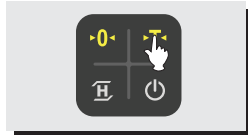

⑤ Press the **T** key, then display will show the "0.000".

3. Changing Unit of Weight (FW500, Unit ver. only)

- Press the **UNIT** key in the simple weighing mode.
You may select kg, lb, or oz as the unit of weight.

4. Hold Function (FW500, Hold ver. only)



① When the weight is unstable, press the **H** key.



② "HOLD" will be displayed twice



③ Then average value will show twice and the "HOLD" function will be removed automatically



5. How to Set the Auto Power Off

Auto-Power-off function automatically power off as time limits.

This function is helpful to save battery, when not in use.

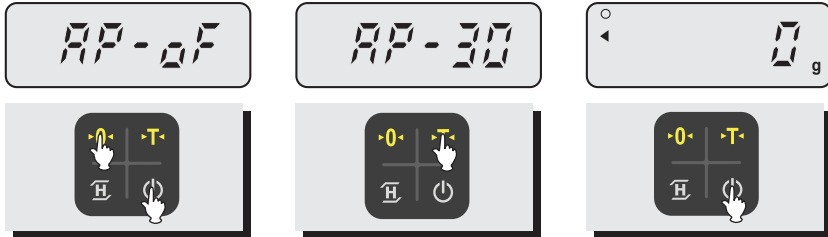
This function is helpful to save battery, when not in use.



① When the scale is turned off press the  key, holding the  key. Press the  key, one more time. You will see the "AP-XX". (If you have set this before, display will show previous value.)

② Press the  key until the display shows the "AP-X0" that you wish to take. (Refer to TABLE 1.)

③ Press the  key twice, the scale saves what you programmed and shows all the segments, counting up "0" to "9".

TABLE 1.

DISPLAY	FUNCTION
AP-oF	This function does not automatically power off.
AP-10	This function does automatically power off when the scale is not in use for 10 minutes.
AP-30	This function does automatically power off when the scale is not in use for 30 minutes.
AP-60	This function does automatically power off when the scale is not in use for 60 minutes.

6. Sleep mode (LED ver.)

The battery life can be extended with this function.

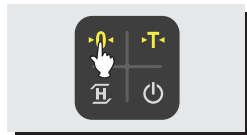
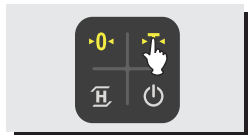

① After activating the automatic power-off feature, the scale displays “SUS60” and goes into the sleep mode. (Refer to TABLE 2.)

② You can browse available values by pressing the TARE key. (Refer to TABLE 2.)

③ Press the ZERO key to select the current value.

TABLE 2.

DISPLAY	FUNCTION
SUSoFF	Turn off the Sleep mode
SUS 20	This function automatically enter the sleep mode after 20 minutes
SUS 40	This function does automatically sleep mode after 40 minutes
SUS 60	This function does automatically sleep mode after 60 minutes

BATTERY MAINTENANCE

LOW BATTERY WARNING

The display shows the “BATT” sign when the battery is low.

You can replace the battery new one.

If you still use the scale without replacing the battery, the scale may provide incorrect result on measurement.



※ Low Battery status.



※ Battery cut off display.

ERROR MESSAGE

Error Message on Display	Description	Solution
"Err 0"	The "Err 0" occurs when the scale is not stable.	Remove unstable facts.
"Err 1"	The "Err 1" occurs when a current zero point has shifted from the last span calibration.	Please call your CAS dealer.
"Err 3"	The "Err 3" is an overload error.	Please remove the weight.

1. Cautions for using Lead-acid battery.

- Be careful your any parts of body to touch terminal of battery. It can be hurt you by Electric shock.
- If battery acid is leaking out, clean it up immediately, acid can be cause of fire.
- For better battery life, operate battery within -15~40°C. If not, Battery life can be half. (The optimum temperature : 20~25°C)
- Avoid sun exposure and keep it in dry area. (Never keep it in wet or dusty environment)

2. Battery run-time

- Battery will be Self-discharge slowly. Even if you don't use a battery.
- Battery is consumables goods. Therefore, If battery amount is decreased, buy a new battery and change.
- Full Discharged battery have to re-charge as quickly as possible.
- You have to fully charge battery before storage it for a long time.

SPECIFICATIONS (FW500-C)

MODEL	FW500-C		
Approval	Max 3/6 kg e=d=1/2 g	Max 6/15 kg e=d=2/5 g	Max 15/30 kg e=d=5/10 g
External Resolution	1/3,000 dual	1/3,000 dual	1/3,000 dual
MAX Tare	-2.999 kg	-5.998 kg	-14.995 kg
Display	106 x 33 mm 5 digit LCD		
Symbols	STABLE, ZERO, TARE, g, kg, lb, oz, Low Battery		
Keys	ZERO, TARE, HOLD(Hold Ver.), UNIT(Unit Ver.), POWER		
Functions	Weighing, WaterProof level IP-69k Hold(Hold Ver.), Sleep Mode Function		
Dimensions	303 x 266 x 109 mm		
Platter size	212 x 247 mm		
Weight	2.7 kg (Without Battery)		
Power	1.5 V x 4 units (D size Battery) or 12 V 300 mA Adapter		
Operation Time	Approx. 1200 h (Manganese battery)/ 2500 h (Alkaline at 20°C /68°F)		
Operating Temperature	-10°C ~ +40°C / 14°F ~ 104°F		
Minimum Voltage Level of The Battery	About 3.3 V		
Option	12 V Adapter 300 mA, Rear Display		

※ Notice: Specifications are subject to change for improvement without notice.

SPECIFICATIONS (FW500-E)

MODEL	FW500-E		
Approval	Max 3/6 kg e=d=1/2 g	Max 6/15 kg e=d=2/5 g	Max 15/30 kg e=d=5/10 g
External Resolution	1/3,000 dual	1/3,000 dual	1/3,000 dual
MAX Tare	-2.999 kg	-5.998 kg	-14.995 kg
Display	77 x 20 mm 5 digit LED		
Symbols	STABLE, ZERO, TARE, g, kg, lb, oz, Low Battery		
Keys	ZERO, TARE, HOLD(Hold Ver.), UNIT(Unit Ver.), POWER		
Functions	Weighing, WaterProof level IP-69k Hold(Hold Ver.), Sleep Mode Function		
Dimensions	303 x 266 x 109 mm		
Platter size	212 x 247 mm		
Weight	2.7 kg (Without Battery)		
Power	6 V 3.2Ah Pb battery , 12 V 300 mA Adapter		
Operation Time	Approx. 100 h (PB battery)		
Operating Temperature	-10°C ~ +40°C / 14°F ~ 104°F		
Minimum Voltage Level of The Battery	About 3.3 V		
Option	12 V Adapter 300 mA, Rear Display		

※ Notice: Specifications are subject to change for improvement without notice.

SPECIFICATIONS (FW500-C)

MODEL	FW500-C		
CAPACITY	6 lb x 0.002 lb / 15 lb x 0.005 lb / 3 000 g x 1 g / 6 000 g x 2 g, 80 oz x 0.05 oz / 160 oz x 0.1 oz	15 lb x 0.005 lb / 30 lb x 0.01 lb / 6 000 g x 2 g / 15 000 x 5 g, 200 oz x 0.1 oz / 400 oz x 0.2 oz	30 lb x 0.01 lb / 60 lb x 0.02 lb / 15 000 g x 5 g / 30 000 x 10 g, 400 oz x 0.2 oz / 1 000 oz x 0.5 oz
External Resolution	1/3,000 dual	1/3,000 dual	1/3,000 dual
MAX Tare	-5.998 lb	-14.995 lb	-29.99 lb
Display	106 x 33 mm 5 digit LCD		
Symbols	STABLE, ZERO, TARE, g, kg, lb, oz, Low Battery		
Keys	ZERO, TARE, HOLD(Hold Ver.), UNIT(Unit Ver.), POWER		
Functions	Weighing, WaterProof level IP-69k Hold(Hold Ver.), Unit Conversion(Unit Ver.), Sleep Mode Function		
Dimensions	303 x 266 x 109 mm		
Platter size	212 x 247 mm		
Weight	2.7 kg (Without Battery)		
Power	1.5 V x 4 units (D size Battery) or 12 V 300 mA Adapter		
Operation Time	Approx. 1200 h (Manganese battery)/ 2500 h (Alkaline at 20°C /68°F)		
Operating Temperature	-10°C ~ +40°C / 14°F ~ 104°F		
Minimum Voltage Level of The Battery	About 3.3 V		
Option	12 V Adapter 300 mA, Rear Display		

※ Notice: Specifications are subject to change for improvement without notice.

SPECIFICATIONS (FW500-E)

MODEL	FW500-E		
CAPACITY	6 lb x 0.002 lb / 15 lb x 0.005 lb, 3 000 g x 1 g / 6 000 g x 2 g 80 oz x 0.05 oz / 160 oz x 0/1 oz	15 lb x 0.005 lb / 30 lb x 0.01 lb, 6 000 g x 2 g / 15 000 x 5g 200 oz x 0.1oz / 400 oz x 0.2 oz	30 lb x 0.01 lb / 60 lb x0.02 lb, 15 000 g x 5 g / 30 000 x 10 g 400 oz x 0.2 oz / 1 000 oz x 0.5 oz
External Resolution	1/3,000 dual	1/3,000 dual	1/3,000 dual
MAX Tare	-5.998 lb	-14.995 lb	-29.99 lb
Display	77 x 20 mm 5 digit LED		
Symbols	STABLE, ZERO, TARE, g, kg, lb, oz, Low Battery		
Keys	ZERO, TARE, HOLD(Hold Ver.), UNIT(Unit Ver.), POWER		
Functions	Weighing, WaterProof level IP-69k Hold(Hold Ver.), Unit Conversion(Unit Ver.), Sleep Mode Function		
Dimensions	303 x 266 x 109 mm		
Platter size	212 x 247 mm		
Weight	2.7 kg (Without Battery)		
Power	6 V 3.2Ah Pb battery , 12 V 300 mA Adapter		
Operation Time	Approx. 100 h (PB battery)		
Operating Temperature	-10°C ~ +40°C / 14°F ~ 104°F		
Minimum Voltage Level of The Battery	About 3.3 V		
Option	12 V Adapter 300 mA, Rear Display		

※ Notice: Specifications are subject to change for improvement without notice.

MEMO

FW500 SERIES

Simple Weighing Scale



CAS BLDG., #1315, YANGJAE-DAERO,

GANGDONG-GU, SEOUL, KOREA

TEL_ 82 2 2225 3500

FAX_ 82 2 475 4668

www.globalcas.com